

Part# OF683XT-E2

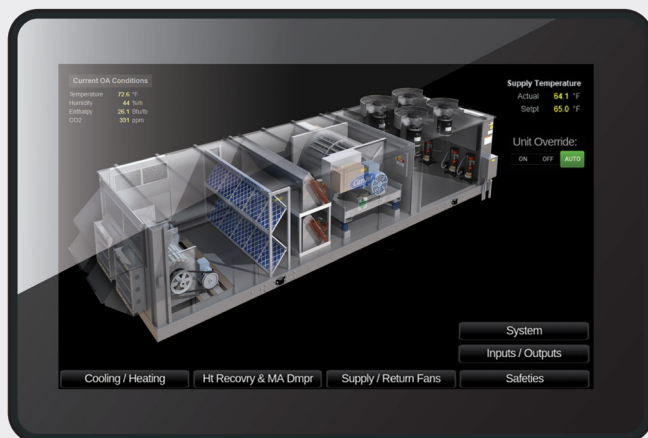

Automated Logic® OptiPoint™ interfaces provide building operators and technicians with visibility and control over a single piece of HVAC equipment in a building. Available in three sizes, they feature an illuminated color, capacitive touchscreen display and are designed to connect to a single WebCTRL® controller, making management of the connected HVAC equipment both intuitive and simple.

### Key Features and Benefits

The user interface features are simple to operate for building occupants, but powerful enough to provide technicians a complete interface for maintaining equipment.

- Capacitive touch screen with best-in-class resolution
- Can be used as a technician tool or occupant interface
- Connects directly to a single WebCTRL controller
- Multi-level password protection for security
- View trends, with added support for pinch/zoom and swiping to move along timeline
- Support for 13 international languages and characters
- Access virtually any point in the controller
- View and edit BACnet time schedules
- View all alarms in controller
- Change setpoints easily
- Visual alarm indicator

### Programming Support

- Easily programmable using ViewBuilder WYSIWYG editor, which includes a library of interactive controls
- Supports standard Equipment Touch files
- Support for graphics and animations
- USB port for local device updates
- Supports screen capture to USB flash drive
- Built-in PDF viewer

### Physical Features

- Rugged, industrial grade display including an IP65 rating on the front of the display and a wide temperature range and vibration resistance
- Fanless cooling system and Ultra-low power consumption
- Available in three sizes: 4", 7" and 10"
- Can be panel or wall-mounted



The WebCTRL® system gives you the ability to understand your building operations and analyze the results. Integrate environmental, energy, security and safety systems into one powerful management tool that allows you to reduce energy consumption, increase occupant comfort, and achieve sustainable building operations.



# OptiPoint™ Interfaces

## Graphical Touchscreen Control Stations

06182020

Part #	Part# EQT2-4 OptiPoint 4" Interface	Part# EQT2-4 OptiPoint 7" Interface	Part# EQT2-4" OptiPoint 10" Interface
Power:	24Vdc, 1A	24Vdc, 1A	24Vdc, 1A
Display:	TFT (Widescreen): 4.3" (11.0 cm) Resolution: 480 x 272 pixels (128 ppi) Brightness: 400 cd/m (typ.) Contrast ratio: 1000:1 (typ.) Viewing angle: -75~50(H); -75~75(V) Max colors: 16.7M (8-bit) Touch: Capacitive Multi-Touch (P-CAP)	7" (17.8 cm) 1024 x 600 pixels (170 ppi) 320 cd/m (typ.) 1000:1 (typ.) -75~50(H); -75~75(V) 16.7M (8-bit) Capacitive Multi-Touch (P-CAP)	10.1" (25.7 cm) 1280 x 800 pixels (149 ppi) 350 cd/m (typ.) 800:1 (typ.) -85~85(H); -85~85(V) 16.7M (8-bit) Capacitive Multi-Touch (P-CAP)
Operating Conditions:	-4°F to 140°F (-20°C to 60°C), 10% to 90% RH (non-condensing) Front IP65 Water and Dust Proof (Rear: IP20); Vibration tested to IEC60068-2-64		
Storage Temperatures:	-13°F to 158°F (-25°C to 70°C)		
Communication:	Comm Input: Ethernet or EIA-485 based serial port for connection to the Rnet network (115kbps) USB: For upgrades, screen captures, and file transfers USB OTG: Micro-USB "On the Go" port for firmware upgrades LAN: Disabled for future use		
System:	OS: Android 6.0 Processor: Freescale Cortex A9 i.MX6 Dual Core 1 GHz System Memory: 1GB LPDDR3 RAM to store variable data and LCD data Storage: 8 GB on-board eMMC flash memory to store program code and screen file		
Mounting:	Wall or panel mounting within the building interior		
Listed by:	CE (Class B), FCC (Class B), UL 60950, Vibration tested to EN60068-2-6, IP65 rated (front) IP20 rated (rear)		
Real-time clock:	A 365-day real time clock/calendar chip. The time and date will be maintained for a minimum of 72 hours after loss of power (at room temperature).		
Device identification:	A serial number label is on the back of the device.		

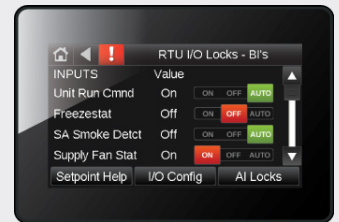

### Ports

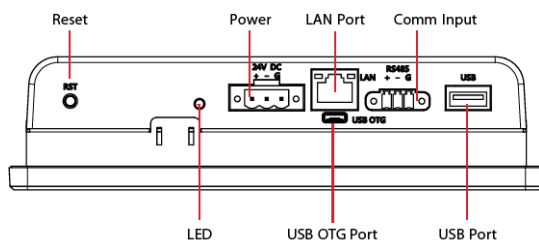

### Physical Dimensions

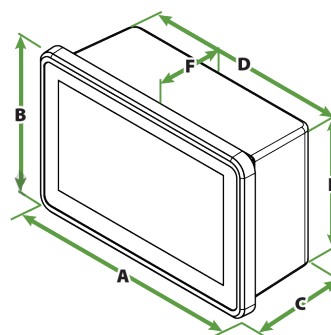

### OptiPoint 4 Interface

A: 121 mm (4.76")	D: 110 mm (4.33")
B: 82 mm (3.23")	E: 74 mm (2.91")
C: 49 mm (1.93")	F: 42 mm (1.65")

### OptiPoint 7 Interface

A: 185 mm (7.28")	D: 175 mm (6.89")
B: 128 mm (5.04")	E: 118 mm (4.65")
C: 46 mm (1.81")	F: 39 mm (1.52")

### OptiPoint 10 Interface

A: 267 mm (10.5")	D: 244 mm (9.61")
B: 182 mm (7.17")	E: 159 mm (6.26")
C: 47 mm (1.85")	F: 39 mm (1.52")



Automated  
Logic